

# Furniture List

The FAR Game: : Constraints Sparking Creativity

	W	L	H	EA
01. Table for Model (Tetris House)	770	370	300	1
02. Table for Model (Streotype Model)	485	465	720	1
03. Table for Leaflet	500	500	950	1
04. Table for 72 Models(1700 X 8000 table)	1,800	4,000	950	2
05. Table for Book	400	2,000	900	2
06. Stool		기성품사용		10
07. TV Table 1	1,250	400	650	2
08. TV Table 2	1,800	400	450	1
09. Exhibition Box	1,000	3,000	2,100	1
10. Table for Seung Woo BACK works	2,400	620	720	2

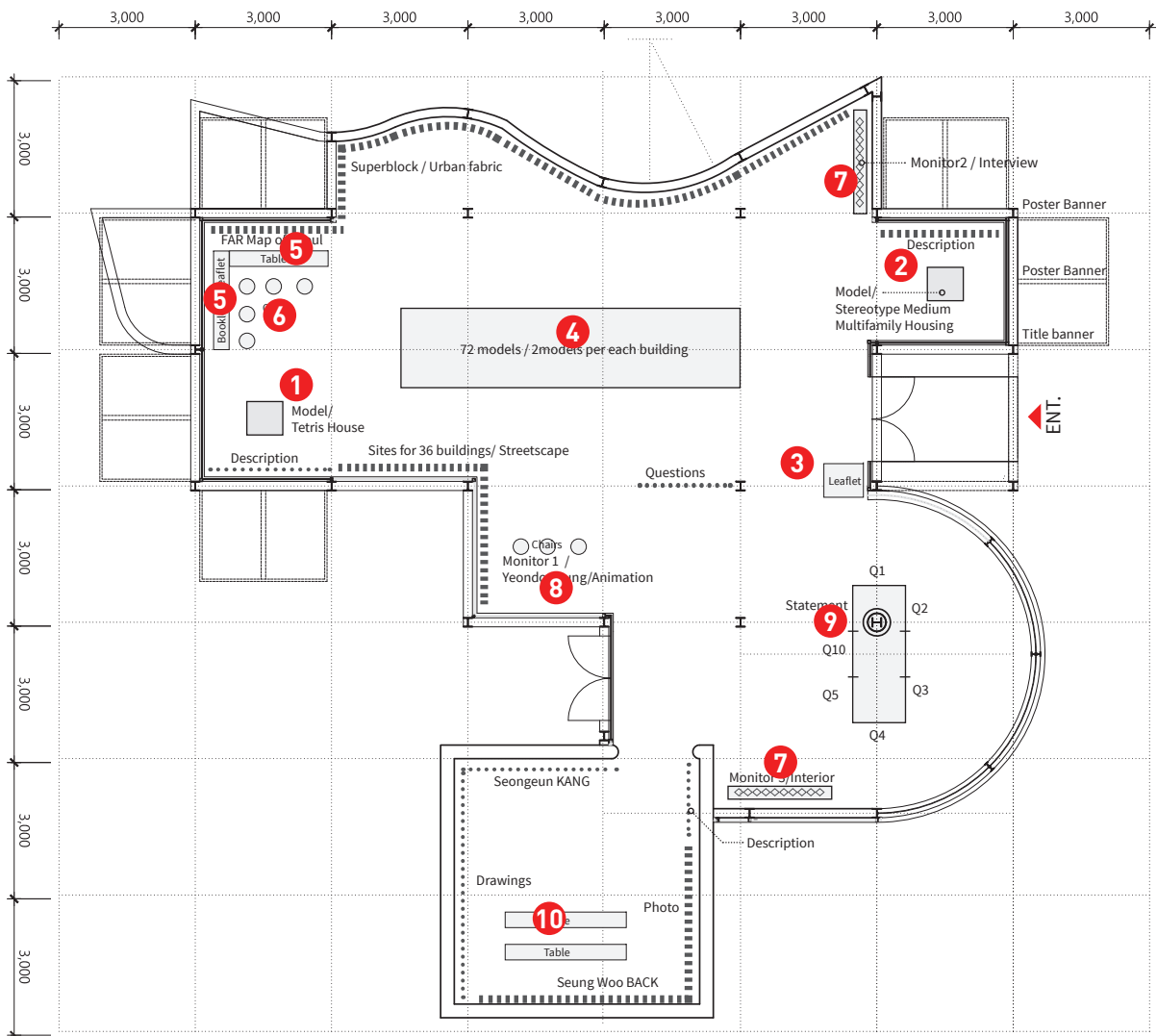

1 . Tabe for Model

SIZE : 770(W) X 370(L) X 720(H)

1 EA

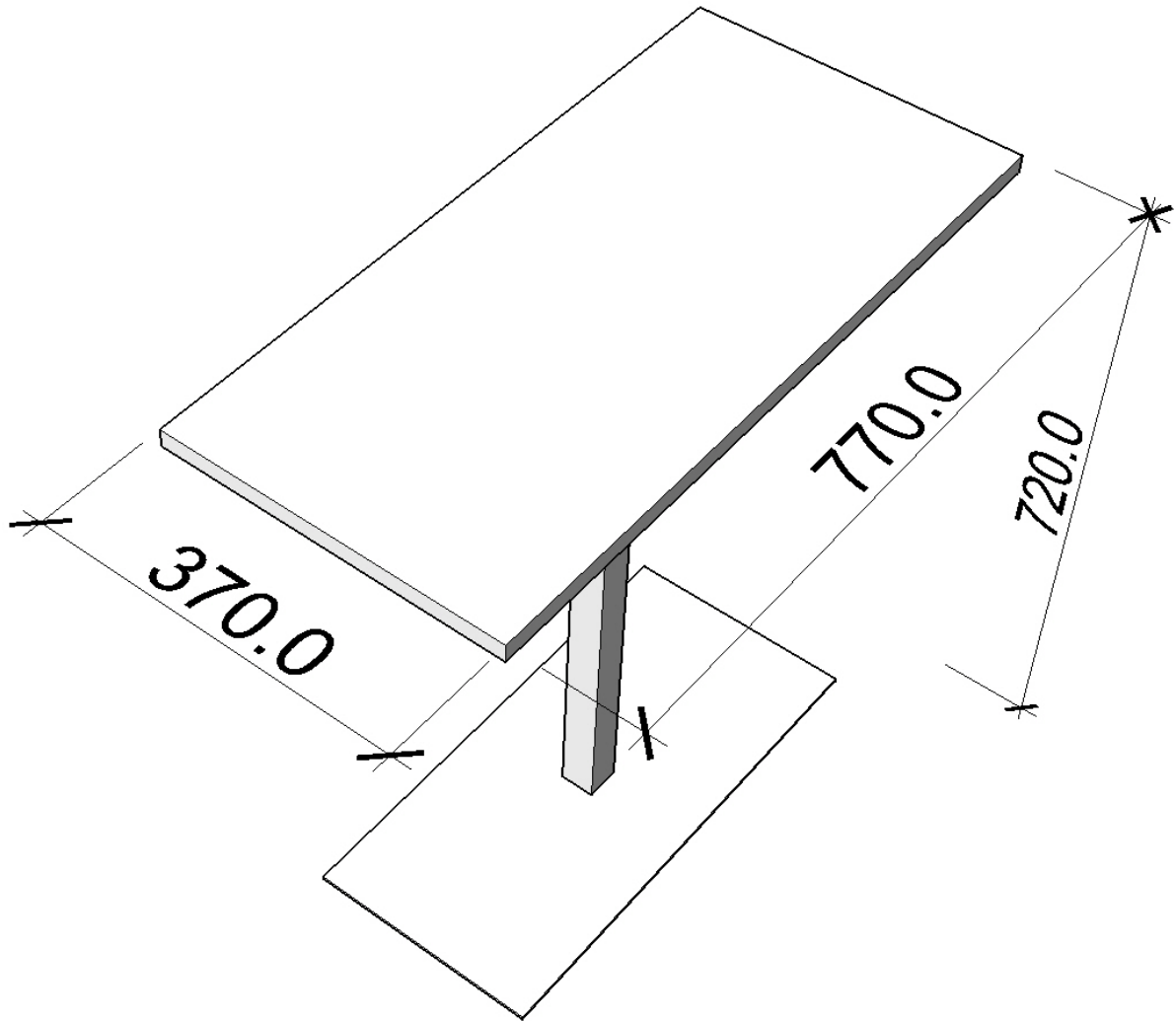

1. 백색도장
2. 테이블위에 올라갈 것은 가벼운 스티로폼모형임.
3. 프레임은 얇으면 얇을수록 좋음
4. 바닥고정판은 안정되게 고려해주시면 됨

2 . Tabe for Model (Stereotype Multi family housing)

SIZE : 485(W) X 465(L) X 720(H)

1 EA

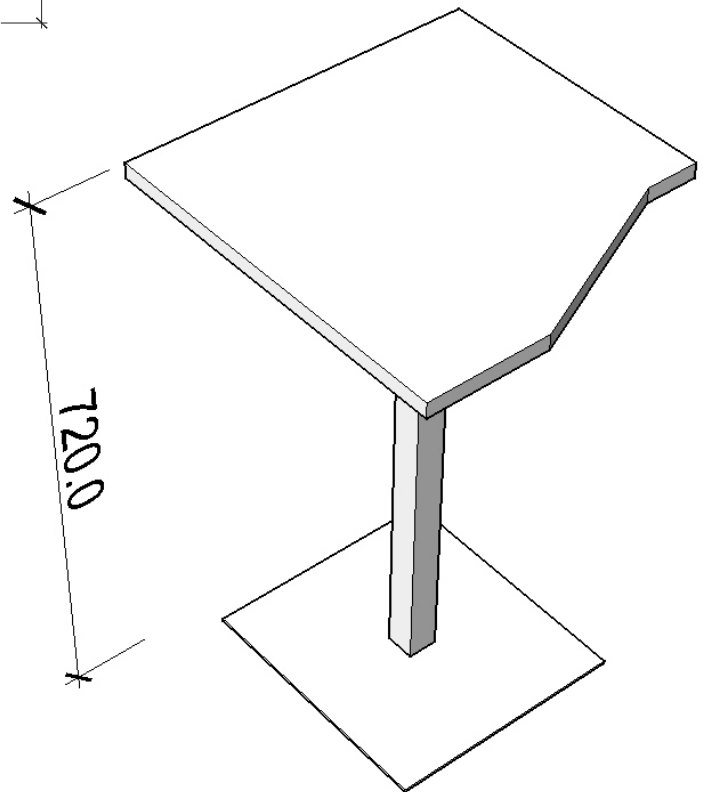
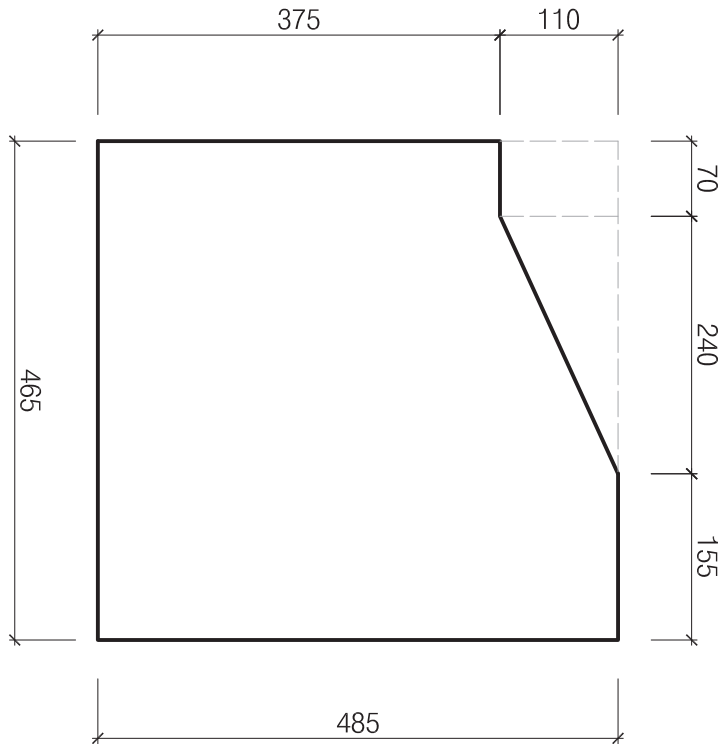

1. 백색도장
2. 테이블위에 올라갈 것은 가벼운 스티로폼모형임.
3. 프레임은 얇으면 얇을수록 좋음
4. 바닥고정판은 안정되게 고려해주시면 됨

3 . Tabe for Leaflet

SIZE : 550(W) X 550(L) X 720(H)

1 EA

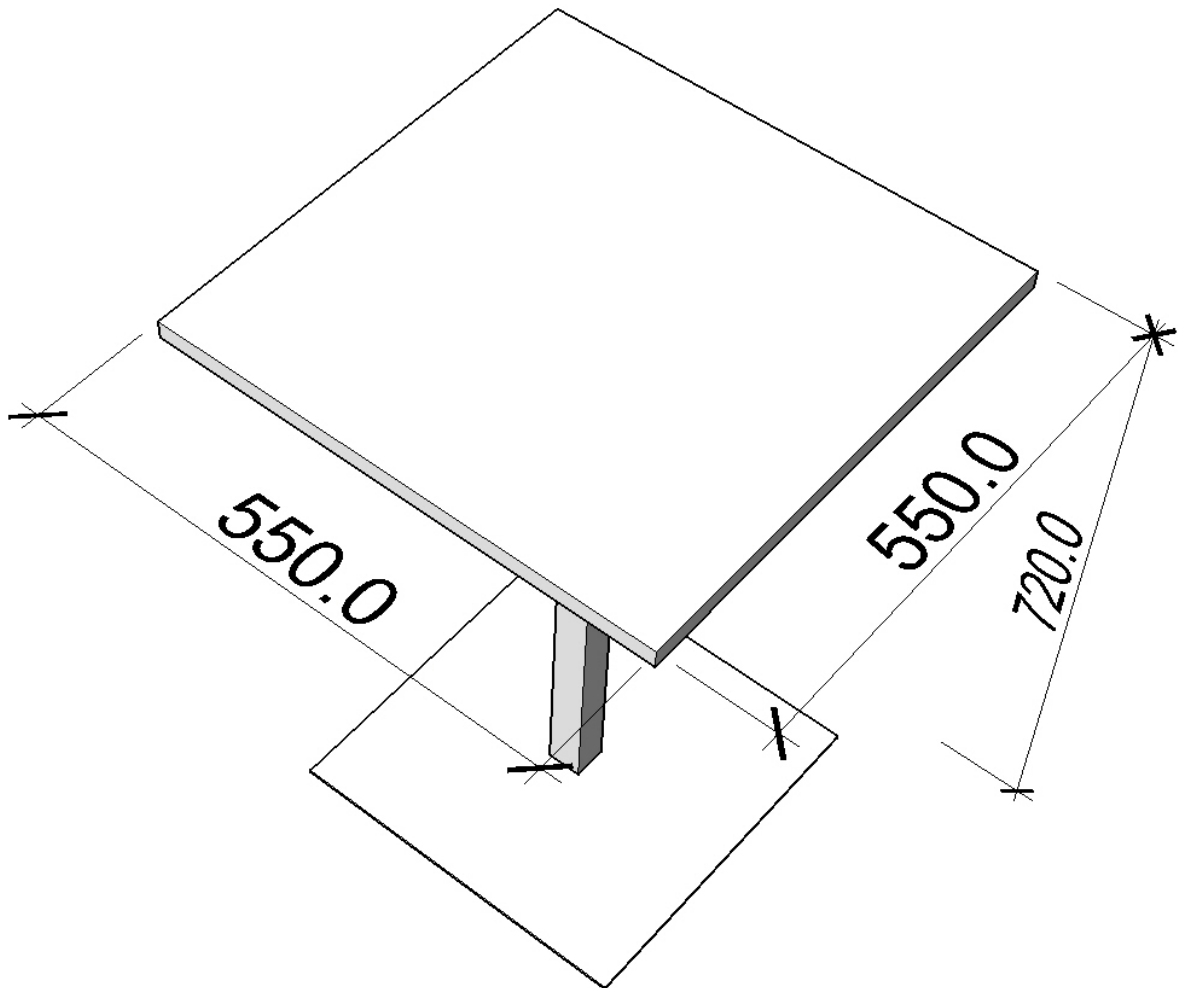

1. 백색도장
2. 테이블위에 올라갈 것은 여러권이 책임.
3. 프레임은 얇으면 얇을수록 좋음
4. 바닥고정판은 안정되게 고려해주시면 됨

#### 4. Table for 72 Models

SIZE : 4,000(W) X 1,800(L) X 950(H)

2 SET

책상 2개 모아놓은 전체 모습

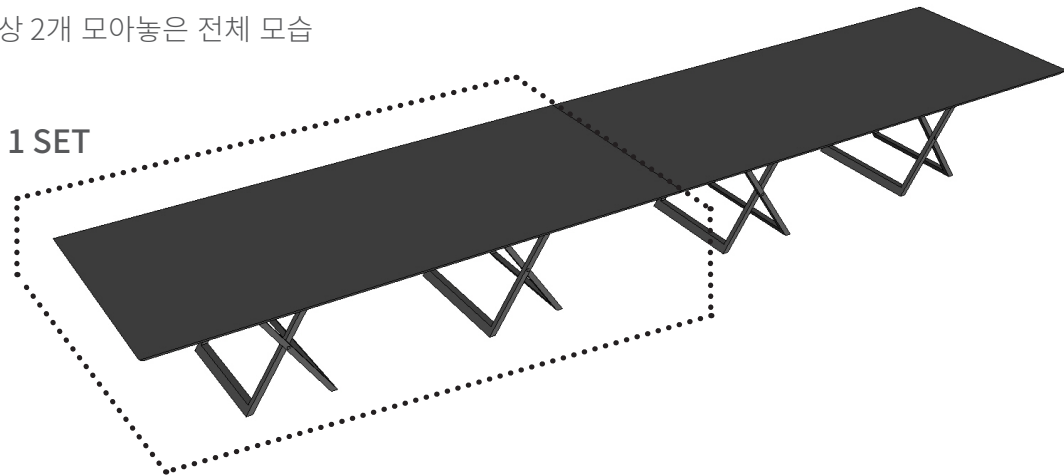

상판

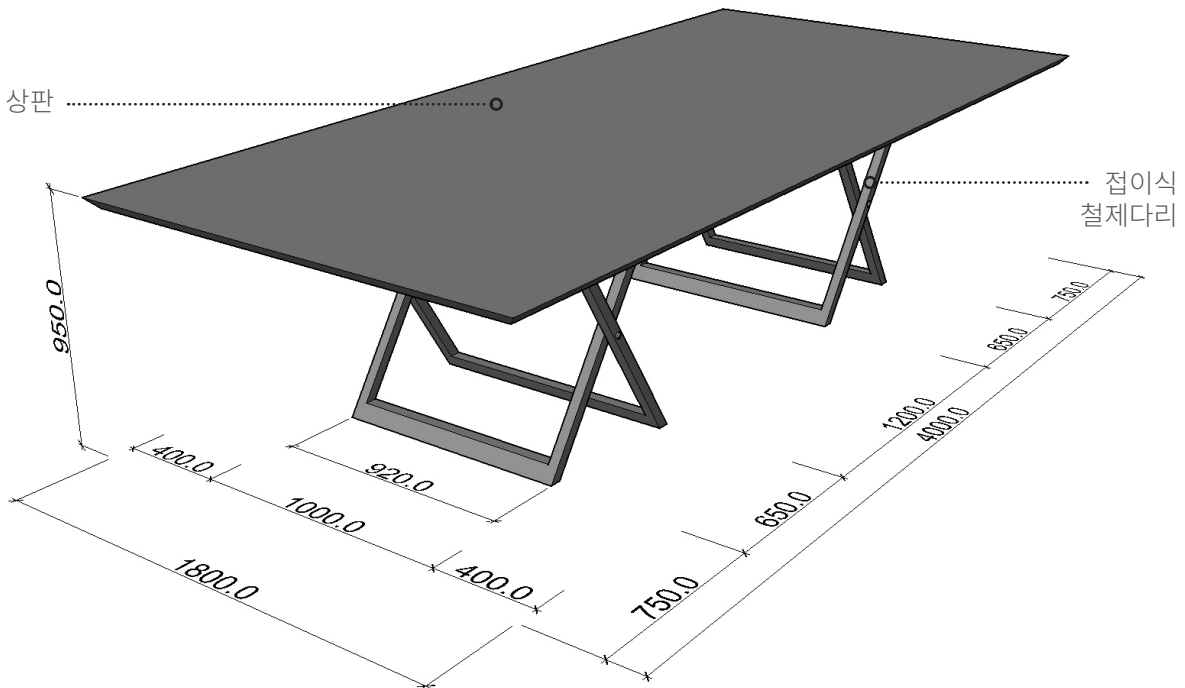

1. 흑색도장
2. 테이블위에 올라갈 것은 스티로폼모형임.
3. 프레임은 얇으면 얇을수록 좋음
4. 바닥프레임에는 높이조절가능한 볼트가 필요함
5. 접이식 철제다리가 부적합할 경우 더 튼튼한 고정형으로 진행가능함(이경우, 혹시 가능하다면 조립식(볼트너트이용)이면 좋음)

## 4. Table for 72 Models

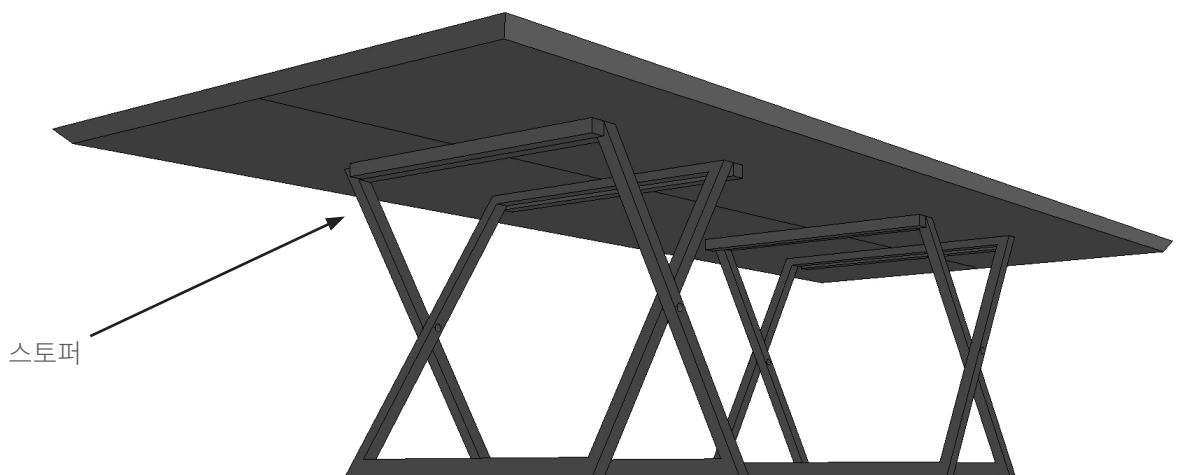
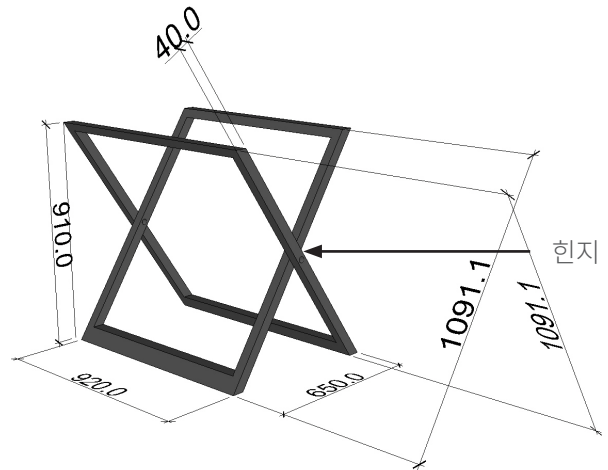

5. Table for Booklet

SIZE : 2,000(W) X 400(L) X 900(H)

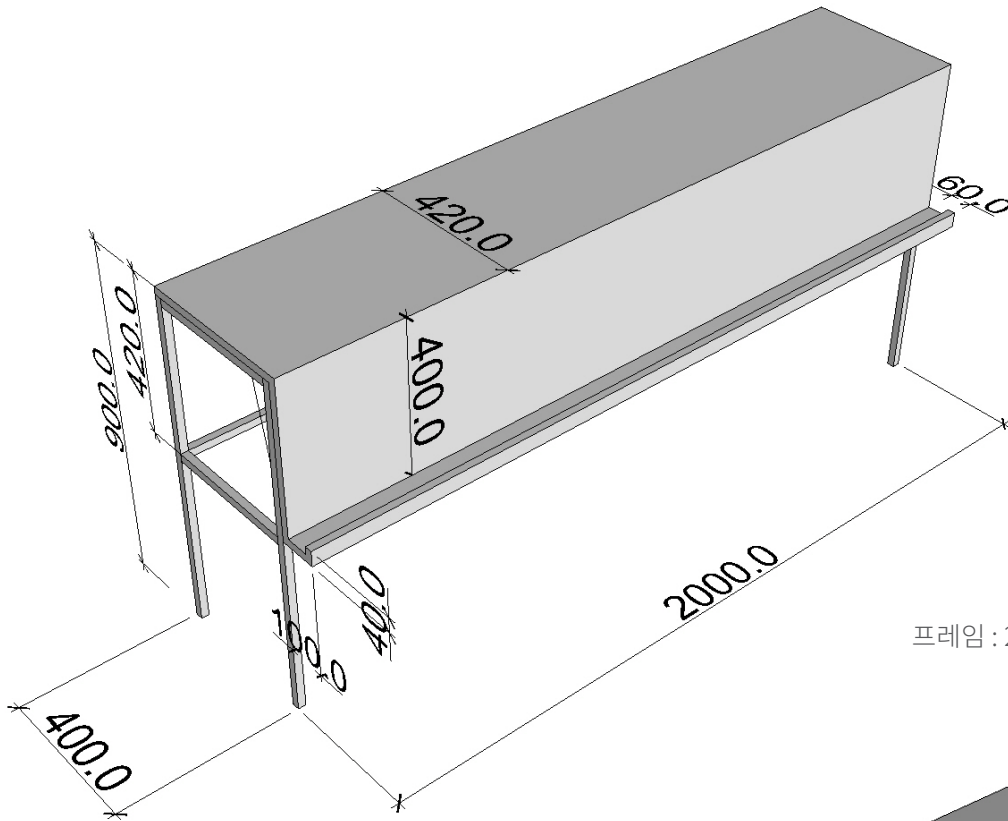

상판두께 : 2cm  
상판 합판, 백색 마감  
프레임 : 2cm X 2cm 각 파이프  
프레임 백색도장마감

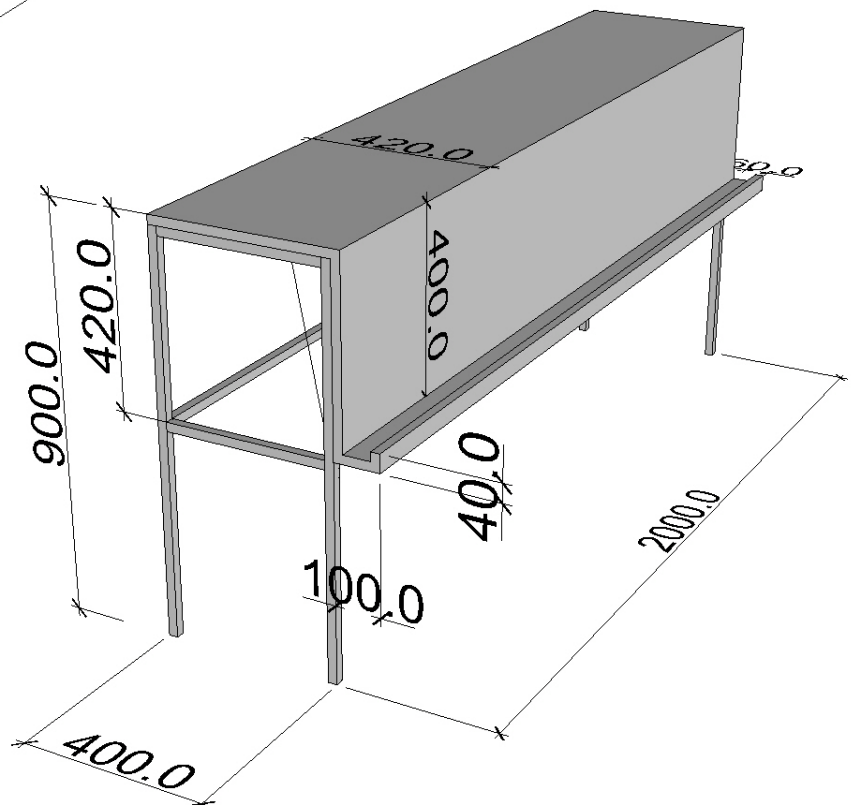

## 6. Stool

기성품사용

5EA



상품번호 : 122994702 [QR코드](#)

스툴의자모음/화장대의자/패브릭스툴/철재스툴/수납스툴/데님스툴

### 01 심플스툴



5EA



상품번호 : 262657760 [QR코드](#)

[이케아/KEA점품 BOSNAS Footstool with storage]BOSNAS  
풋스툴/스툴/수납스툴/이케아가구/KEA

국내 최대 IKEA 구매대행 전문기업

**23,900원**

예상카드  
청구할인가 **22,700원** (현대카드) [청구할인카드 더보기](#)

**Pay 간편결제 카드/계좌 첫 사용 시 포인트 1,000원 즉시 적립!**  
[자세히보기 >](#)

구매혜택 추가 적립 포인트 최대 **239원** [?](#)

구매평작성 포인트 최대 **150원** [?](#)

무이자월부 [자세히보기](#)

배송방법 택배

배송비 4,000원 (1개마다 부과 / 제주, 도서지역 추가 4,000원)

배송비결제 주문시 결제

옵션



7 . TV Table 1

SIZE : 1,250(W) X 400(L) X 650(H)

2 EA

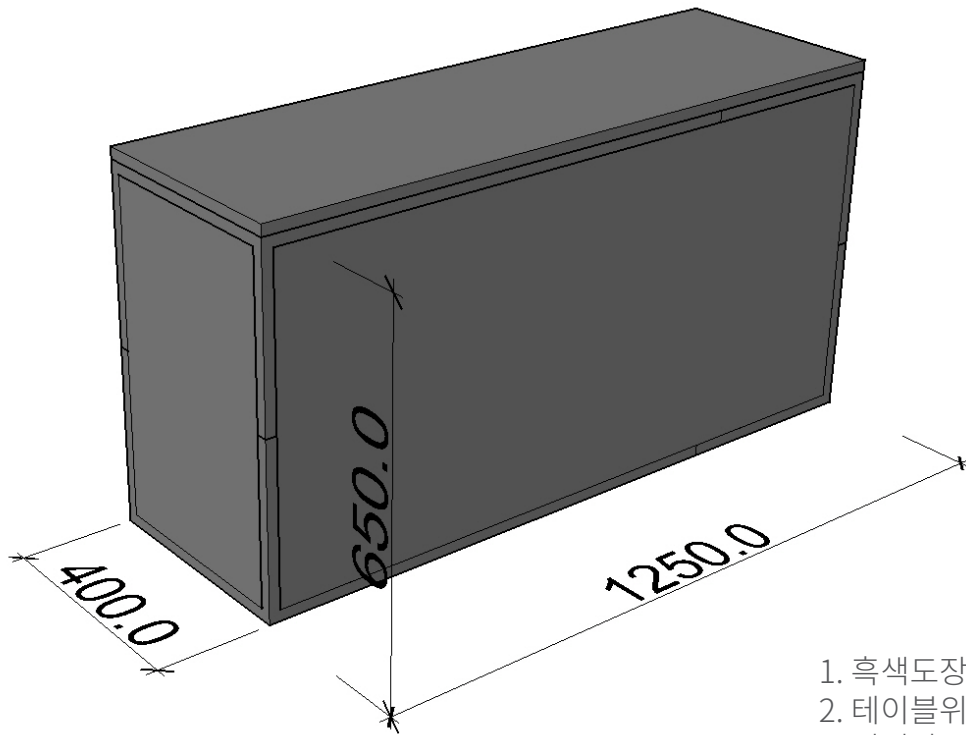

1. 흑색도장
2. 테이블위 TV 올릴예정
3. 정면과 옆면은 막혀있고, 뒷면만 열린 구조

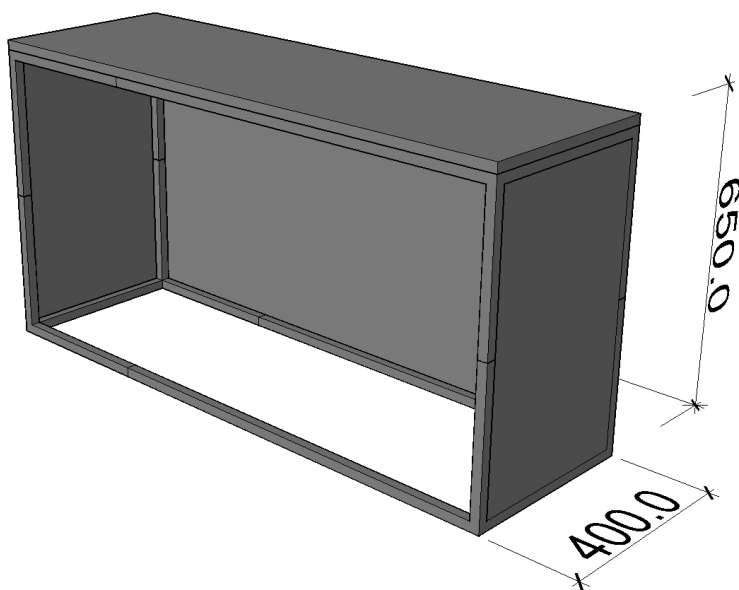

8 . TV Table 2

SIZE : 1,800(W) X 400(L) X 400(H)

1 EA

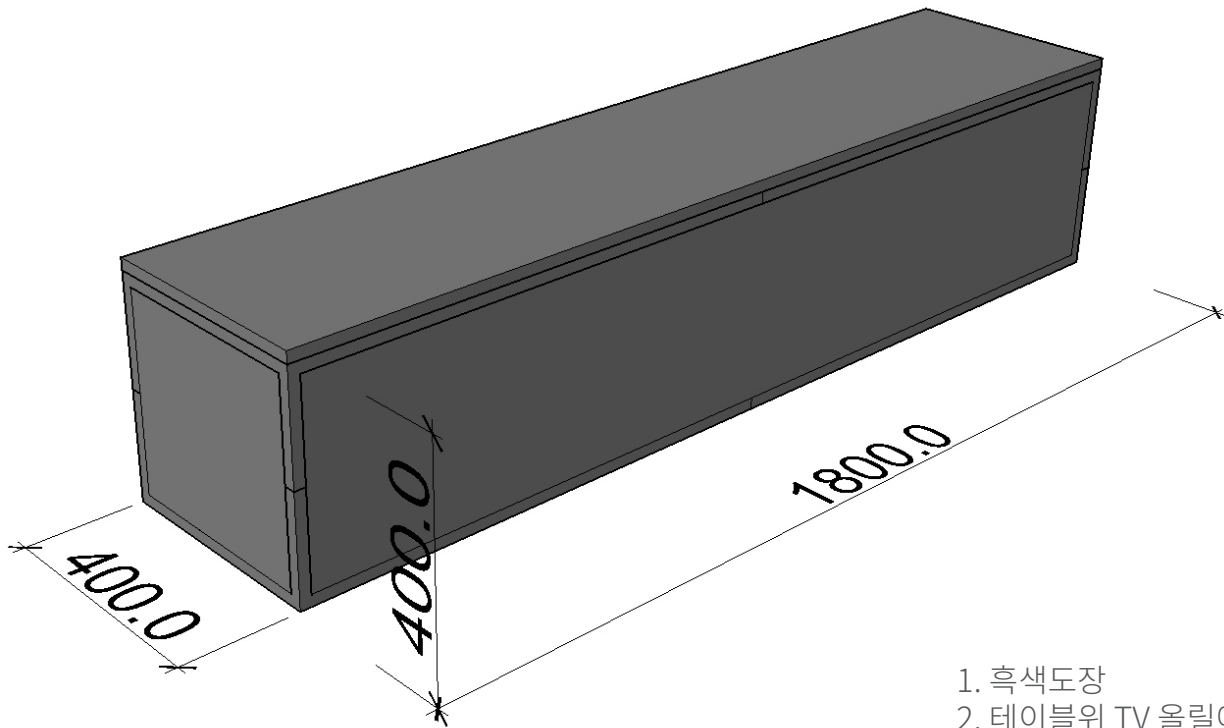

1. 흑색도장
2. 테이블위 TV 올릴예정
3. 정면과 옆면은 막혀있고, 뒷면만 열린 구조

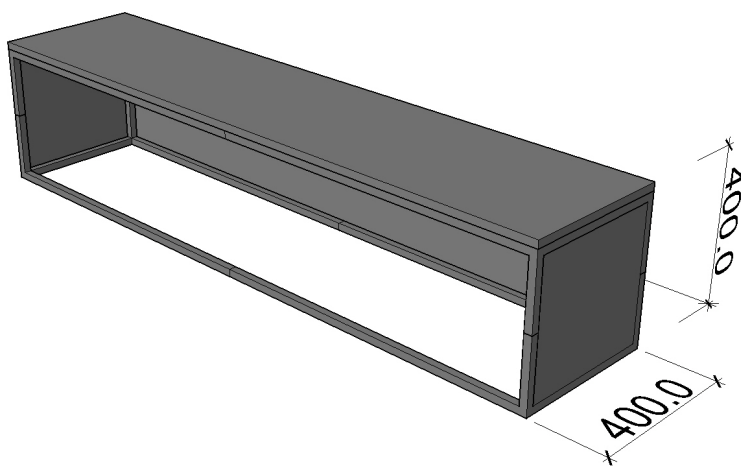

검정색 도장

## 9. Exhibition Box

프레임 2개 SIZE : 1,500(W) X 1,000(L) X 2,100(H)

부착판 8개 : 2,000(W) X 1,000(L) 두께는 10T

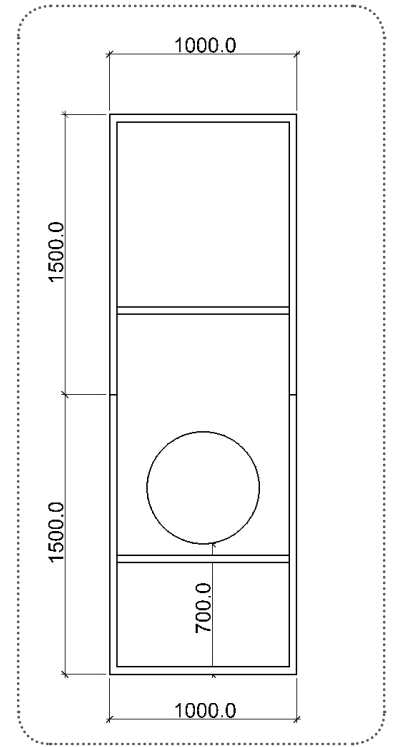
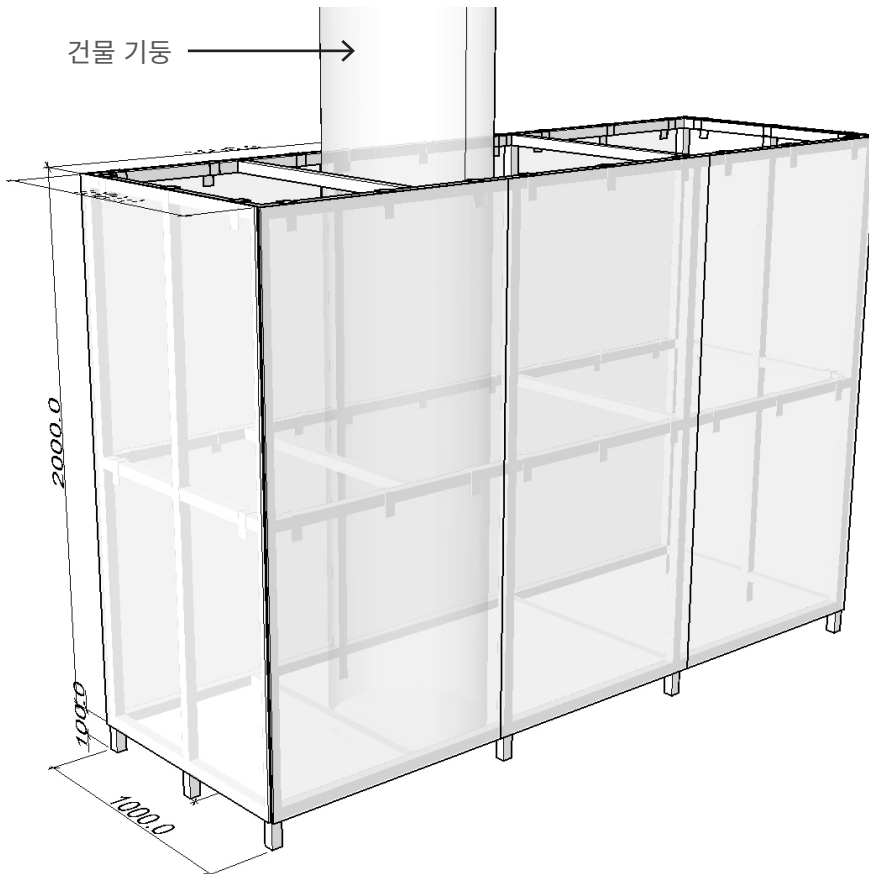

평면부

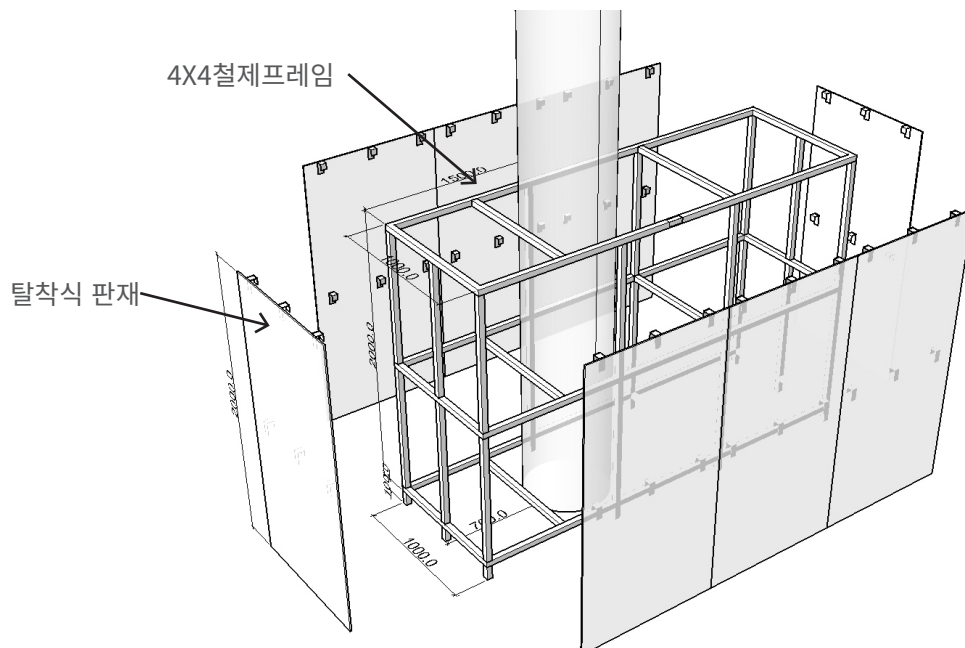

8. Exhibition Box

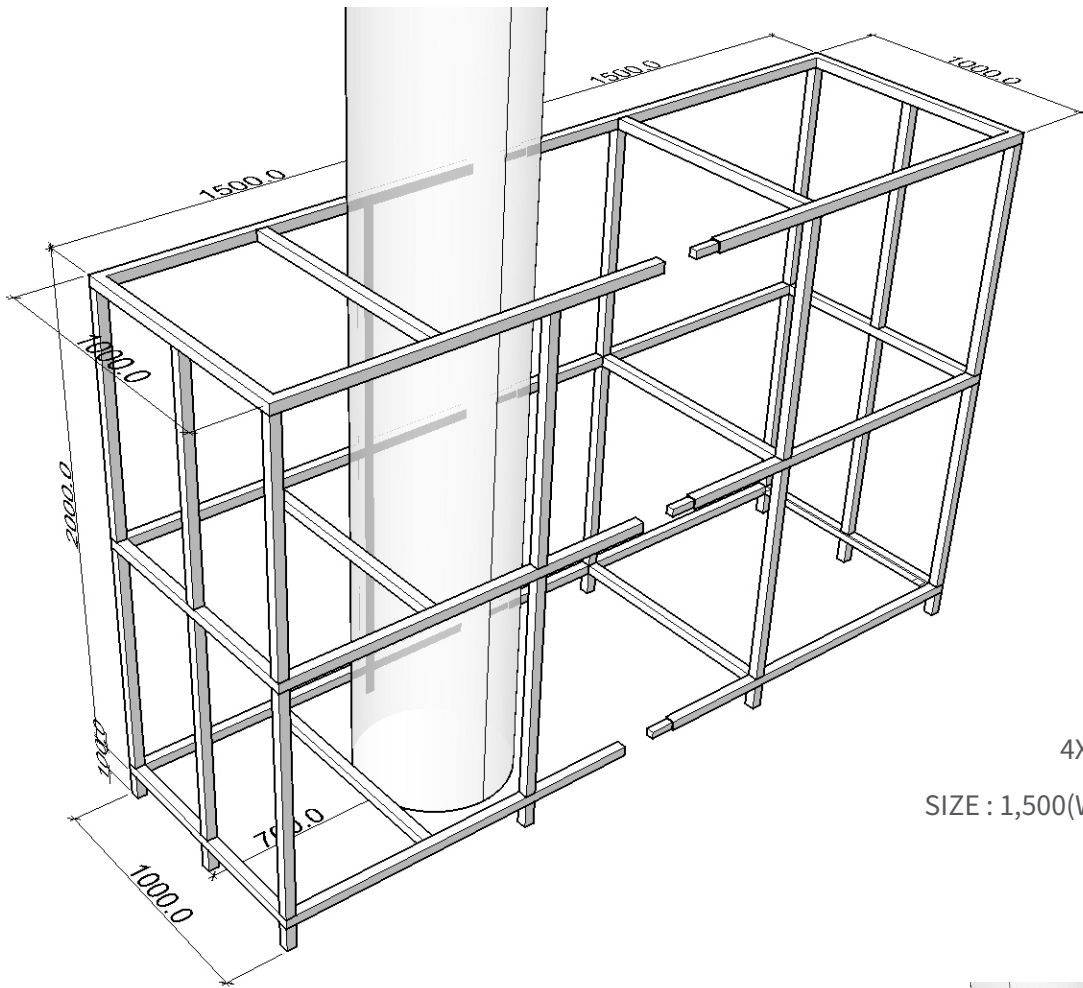

4X4각파이프 프레임  
가운데 기둥으로 인해,  
반으로 나누어  
연결 가능하도록 제작

4X4각파이프 프레임 조립전  
SIZE : 1,500(W) X 1,000(L) X 2,100(H)  
2EA  
파이프 검정 도장

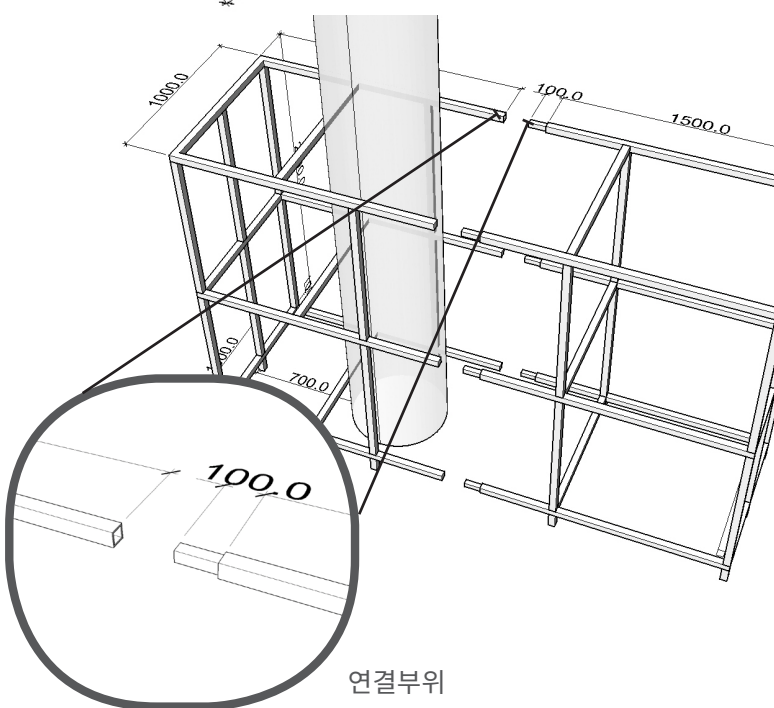

연결부위

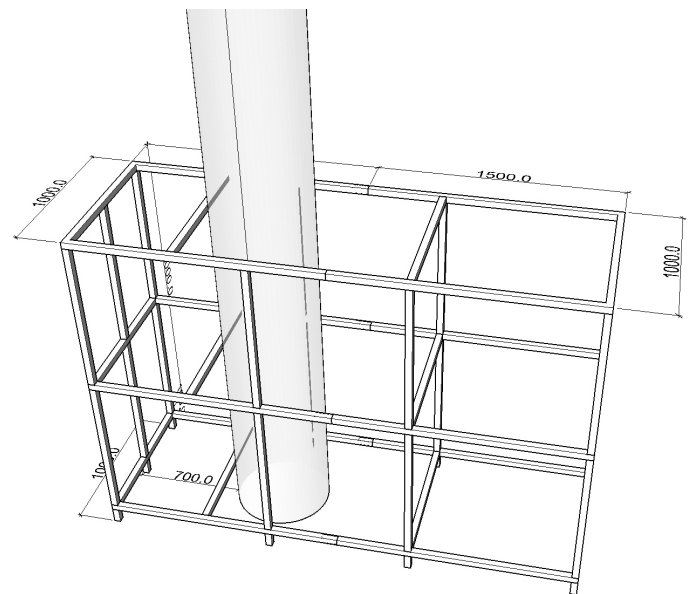

연결된 모습

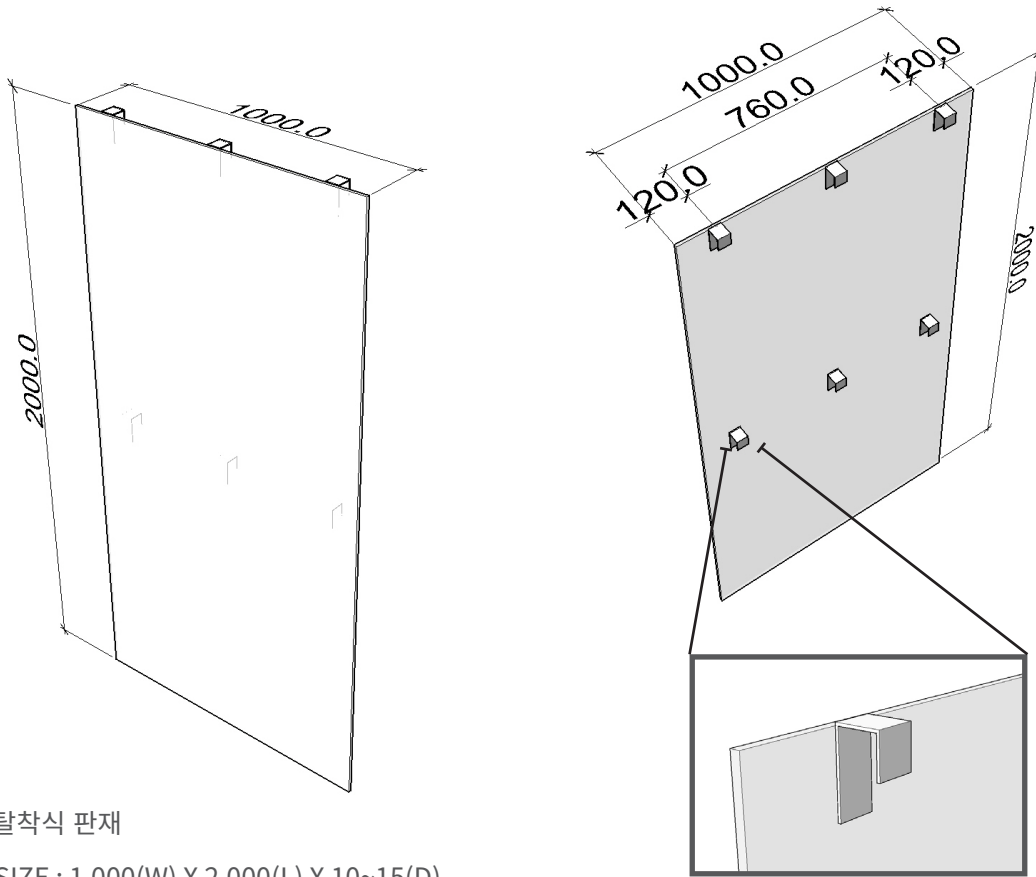

탈착식 판재

SIZE : 1,000(W) X 2,000(L) X 10~15(D)

판재 : 포맥스 혹은 MDF(?)  
 스틸프레임에 거는 걸쇠 부착 방식에 따라 조정  
 백색마감

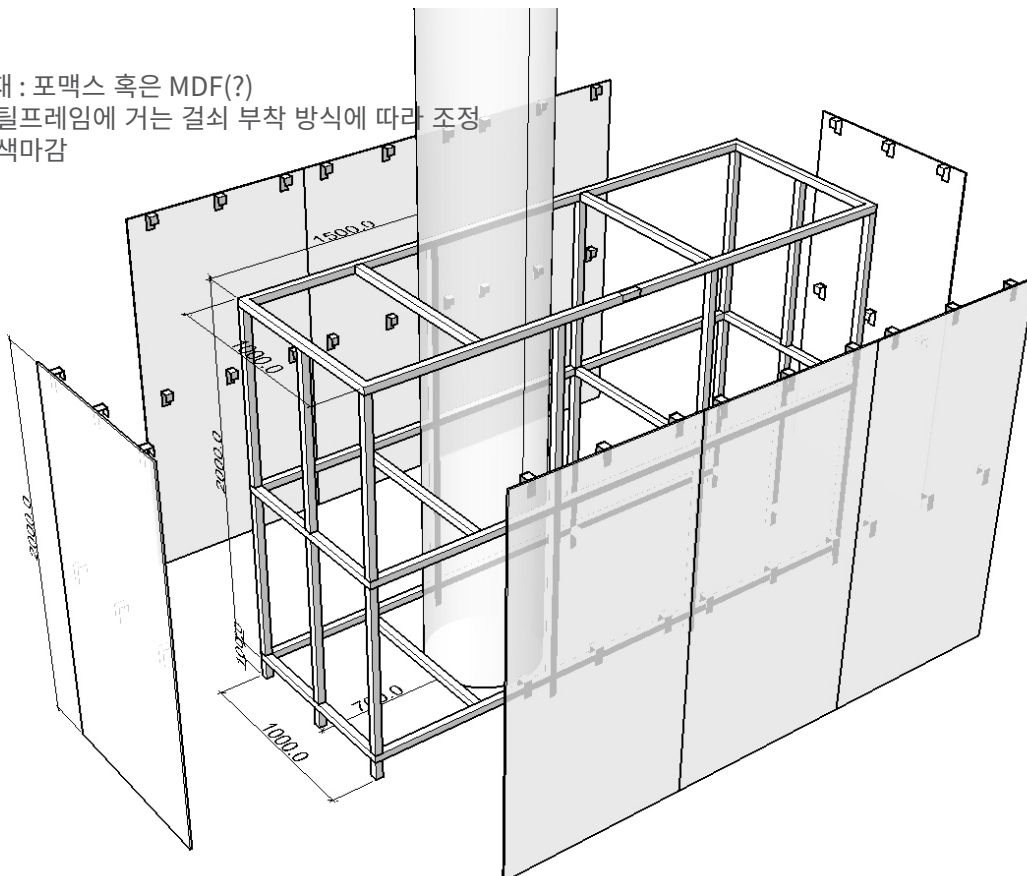

---

## 10 . Tabe for Seung Woo BACK

---

SIZE : 2,400(W) X 620(L) X 720(H)

2 EA

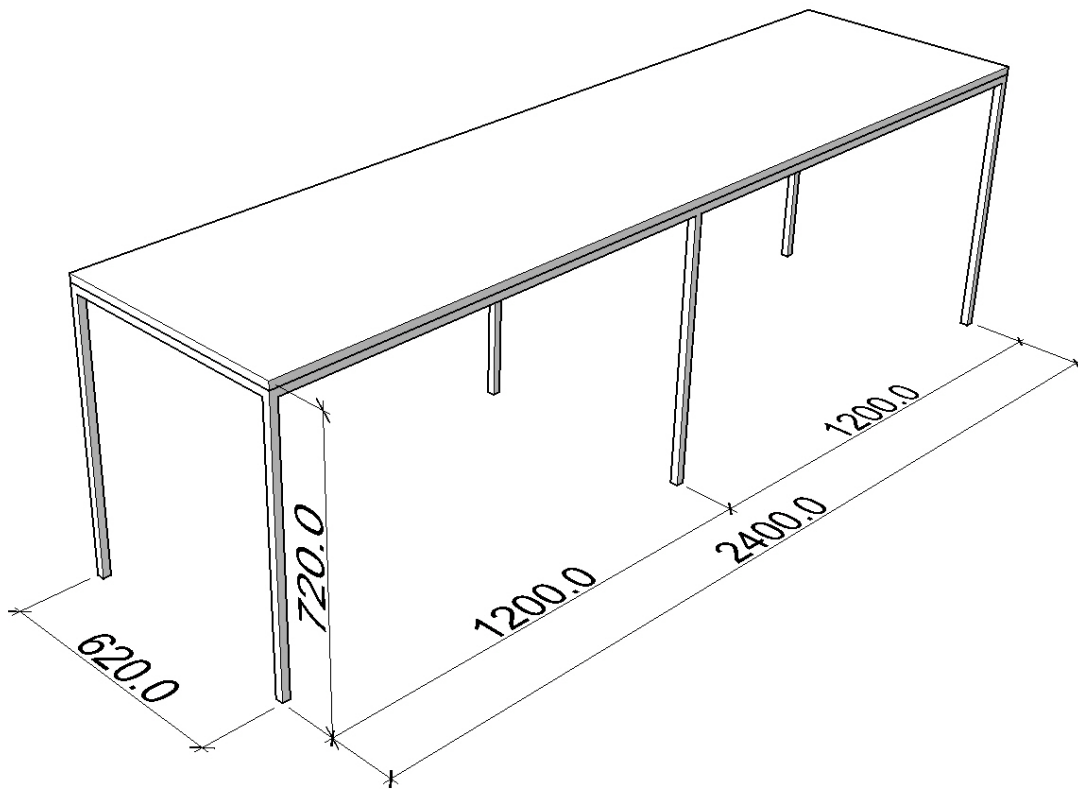

1. 백색도장
2. 테이블위 아주 가벼운 프린트물 올릴예정
3. 가운데 다리를 없앨수 있다면 좋음.